

Car Park and Landscape Design



Introduction

This Guidance Note covers the main aspects of landscape design and planning around small sports facilities although the principles apply to all building facilities. For a sports facility to function efficiently it is essential that the design of the landscape and external spaces is considered at the outset. The allocation of sufficient funds to this aspect of the overall design will result in:

- an attractive and inviting environment that people enjoy
- improved long-term appearance of the facility
- reduced running and maintenance costs.

Design briefs for a sports facility must always include the following requirements:

- adequate funds allocated to external works and landscape design
- measures taken to minimise long-term maintenance and repair
- the design promotes safety and security
- the design promotes access by all sections of society
- consideration of the overall shape, colour and form of the buildings, and their surrounds, to create an inviting environment that will attract users
- consideration of sustainability issues.

For the best results a chartered landscape architect should be appointed.

The consequences of ignoring the design of the external environment can be costly and severely affect the long-term viability of a facility by discouraging users or increasing maintenance costs to an unsustainable level.



First impressions of a building are created by the surrounding landscape.



Strategic planning

User profile

The potential range and types of visitor must be examined at the strategic planning stage. A combination of several, or all, of the following groups will have to be accommodated:

- casual visitors
- participants
- organised groups (including school parties)
- spectators.

The physical requirements of users will be further influenced by the need to consider the likely programme of usage that will be employed:

- For whom are the facilities being developed?
- Will use be year-round or seasonal?
- Will there be competitions and organised spectator events?
- Will use be by day and night?
- Will schools and clubs use the facilities?

Location

Locate the facility with a view to encouraging participation. A new sports facility should be located to be easily accessible to a range of potential users and, ideally, in a prominent position. This can be assisted by:

- Finding a site central to a catchment area or close to a busy thoroughfare.
- Locating the facility in an easily accessible and visible place.
- Promoting all forms of transport access including public transport, bicycle and on foot.

When analysing the suitability of a site ensure that:

- There is sufficient space for the proposed facility and space for future expansion.
- There is adequate space for car parking based on local authority standards and any potential overflow requirements.
- Access is available for service and emergency vehicles.

Existing conditions

The character of a sports facility will be influenced by its location, whether it is to contribute to an existing urban streetscape, or be located in a parkland setting. Initially the site will need to be analysed in the light of the expected usage and potential restrictions. Making the most appropriate decisions when planning the site will maximise value for money. The features and planning issues that will inform the site layout are:

- Existing site: slopes, water and structures.
- Existing planting: all trees must be surveyed and their condition and amenity value assessed by a competent person such as an arborist. Identify trees and other types of vegetation to be removed or retained. Establish whether tree preservation orders exist.
- Site boundaries/perimeters: establish locations and find out who owns the neighbouring land.
- The existence of rights of way and easements.
- Context: consider indigenous materials and plant types.
- Town planning issues.
- The location of main services.
- Access and security: visibility, lighting, roads and footpaths.



Robust detailing and careful composition in an urban environment.

Physical requirements of proposals

Requirements of the activities to be located on the site:

- Orientation: building entrances should be orientated away from the direction of the prevailing wind. Viewing positions should not face the setting sun. Pitches should be orientated to avoid low sun angles.
- Car parking requirements.
- Protection of users from the elements: sun, rain and wind.
- Views into the site or features that may need to be highlighted or screened according to use.
- Maintenance requirements: costs and long-term sustainability. For example, reducing the requirements for day-to-day maintenance and replacement of items.

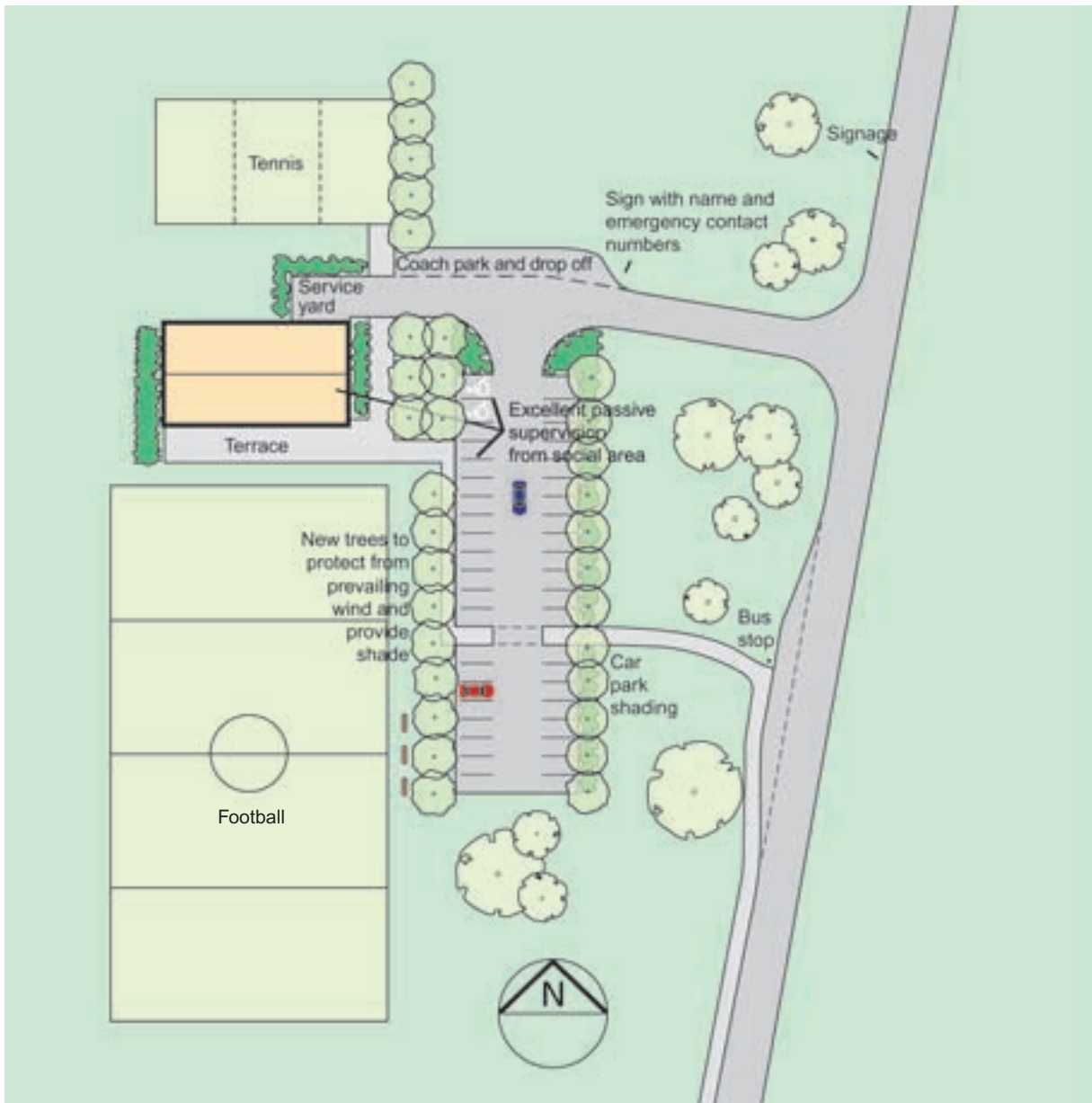

A landscape design includes the layout and orientation of the sports facilities including detailed design of car parking, access routes, signage and planting.



External access

Access to sports facilities should be obvious and easy for all users. The sports facility and its main entrance should be clearly recognisable and well signposted from the access route. Generally, user provision falls into three broad categories:

- users: casual visitors, participants, organised groups and spectators
- operational staff
- services and emergency access.

Sites should be designed to achieve minimum conflict between users arriving on foot, by bicycle or by vehicle. Fully integrated provision must be made for disabled visitors.

Pedestrians

Provide safe, suitably surfaced routes into the site with adequate lighting. Do not expect pedestrians to share the road and avoid, as far as possible, causing pedestrians to cross vehicular routes. Surfaces for pedestrian use should be smooth and even, suitable for buggies and wheelchairs.

Provide external assembly areas for teams and groups of children and, if possible, cover some of these.



A dedicated footpath with olfactory and tactile information will assist visually impaired people.



Cycle parking close to the entrance should have a canopy.

Cyclists

Access roads should be wide enough for cyclists and passing traffic. If necessary provide a separate cycle track with its own entrance. It is important to discourage cyclists from using the pavements or pedestrian areas. Dry, secure bicycle parking and locking up facilities should be provided close to the entrance. The ideal is for bicycle parking facilities to be within sight of reception. The building canopy can be extended to provide sheltered parking. Provision of safe cycling facilities and routes is especially important for children.

Vehicular access

Access from the highway, routes in and out of the site, and the location and planning of the car park will influence the success of the project and the safety of its users. Proposals should always be discussed with local authority highway engineers and, in some cases, traffic/environmental impact studies will need to be carried out.

Car parks

Most local planning authorities have specific car parking standards and these vary between authorities.

The user profile will give a good indication of the need for parking provision, including whether parking and turning space is required for coaches, minibuses and so on. It may be that the facility has the occasional need for overflow car parking for special events or big match days. Dependent on layout and visibility traffic speed control mechanisms, such as speed bumps, may need to be introduced.

In all cases car parks need to accommodate visitors of differing abilities. Requirements include:

- Smooth, hard surfaces. Unbound surfaces such as gravel are not suitable.
- Dedicated parking bays that comply with the minimum standards for disabled people. At least 5% of all car parking bays must be reserved for disabled visitors. They must be clearly identified, both on the bay surface and with a vertical sign immediately adjacent to the bay.
- Illumination that avoids the creation of contrasting pools of light and darkness.
- Safe pedestrian routes, with dropped kerbs, from the car park to the building.
- A drop-off bay adjacent to the main entrance that is long enough to allow 'tail loading'.
- Gathering points for coach drop-offs.

In addition vehicles need to access the building for deliveries, servicing and emergencies, and hardstanding next to the appropriate entrance must be provided.

When planning the car park consider more than simply the car park surface and cars. Bear in mind the visual impact it will make, often greater than that of the facility itself. Provide for planting, shade by trees, safe access across and around the car park. Ensure that the design is linked to, and enhances, the appearance of the building.

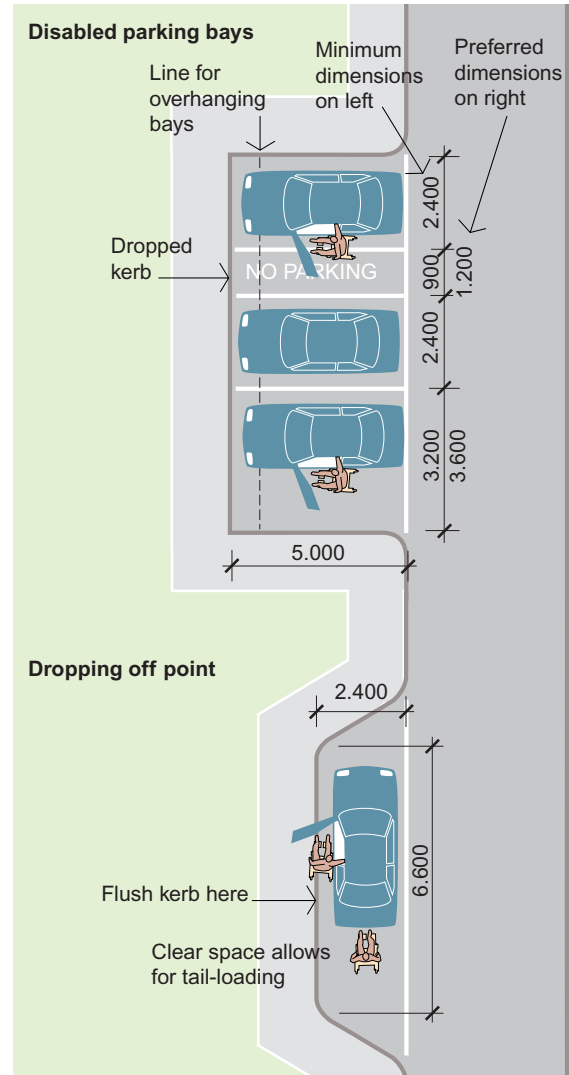

Car parking bay and loading bay dimensions.



Use planting to improve the visual appearance of the car park and to provide shade.

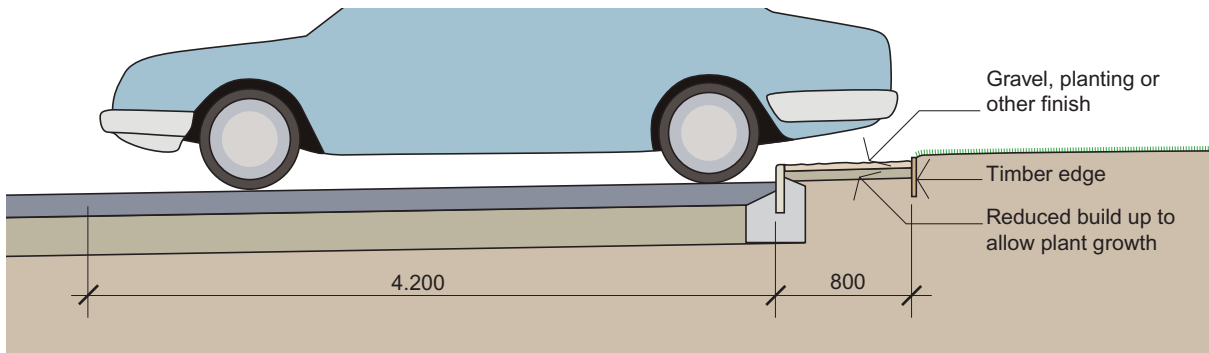

Typical section through overhanging strip.

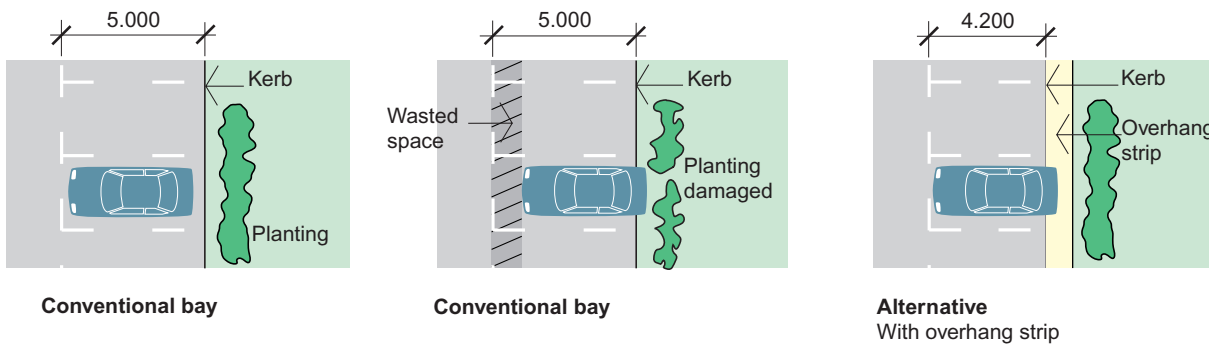

Car park overhang strips reduce the cost of hard surfaces and limit damage to the surrounding planting.

Security

Security means the protection of users as well as the protection of facilities from vandalism, abuse and misuse. The keys to good site security are:

- Visibility in and out of the site.
- Visibility within the site and the use of passive supervision, that is to say windows overlooking potentially vulnerable areas and the reception overlooking the car park and service areas.
- Adequate lighting of main routes in and out of the building including car parks.
- Appropriate height and location of planting.
- Good general ambience around the facility.
- The design of buildings and external layout to avoid the inclusion of corners that can conceal people by day or night.

Hard surfaces – detail design

'Hard landscape' is the term sometimes given to anything built outdoors such as paving, roads, steps and walls.



Materials

A vast range of materials in different finishes and colours is available for paving purposes. Selection must be based on engineering and aesthetic qualities and successful application will depend on good detailing and thorough understanding of the product.

Avoid loose cobbles or stones that can be removed or thrown, and ensure that loose gravel is not used where it will inhibit access for disabled people. The following list is not exhaustive, rather it gives a general introduction to some of the more easily available materials.

Material	Comments
<p>Bitumen: smooth</p> 	<p>Use: Roads, footpaths and cycle paths</p> <p>For: Low cost Easy to repair Available in a variety of colours and finishes</p> <p>Against: Poor visual appearance if not well planned and detailed Short lifespan</p>
<p>In situ concrete: textured</p> 	<p>Use: Roads, footpaths and cycle paths</p> <p>For: Low cost Good visual appearance if detailed correctly</p> <p>Against: Poor visual appearance if detailed incorrectly</p>
<p>Concrete slabs: smooth or textured</p> 	<p>Use: Footpaths and light traffic</p> <p>For: Good visual appearance if detailed correctly</p> <p>Against: High cost Liable to break if not detailed correctly</p>
<p>Concrete blocks: smooth or textured</p> 	<p>Use: Roads, footpaths and cycle paths</p> <p>For: Hard-wearing Low maintenance</p> <p>Against: High cost</p>

Paving materials: an overview.

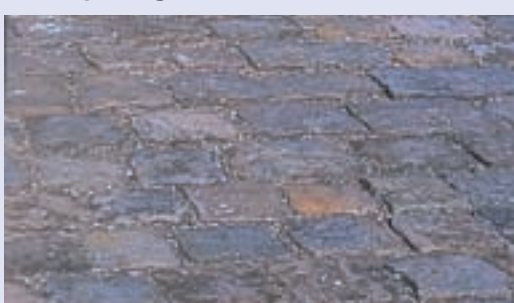
Material	Comments
<p>Shingle unbound: textured</p> 	<p>Use: Footpaths</p> <p>For: Good visual appearance</p> <p>Against: Maintenance required Difficult surface for wheelchairs and pushchairs Vulnerable to vandalism</p>
<p>Aggregate resin bound: textured</p> 	<p>Use: Light traffic and footpaths</p> <p>For: Good visual appearance Low maintenance</p> <p>Against: High cost</p>
<p>Clay/brick paving: smooth or textured</p> 	<p>Use: Roads, footpaths and cycle paths</p> <p>For: Good visual appearance Low maintenance</p> <p>Against: High cost</p>
<p>Stone paving: smooth or textured</p> 	<p>Use: Footpaths</p> <p>For: Good visual appearance Low maintenance</p> <p>Against: High cost</p>

Paving materials: an overview (continued).

Footpaths

Generally, main footpaths should be wide enough to allow two wheelchairs to pass comfortably. The norm is 1.8m and 1.0m is an absolute minimum at pinch points. If footpaths are too narrow or have sharp-cornered junctions, wear will occur on adjacent grass areas. Junctions with other footpaths should be splayed or rounded. Routes across roads or parking areas must include dropped kerbs, and tactile surfaces should be used to warn people with visual impairment of impending dangers such as vehicular routes.

Footpaths should have a maximum gradient of 1:20 with flat pauses at intervals of no more than 8m. If a footpath is steeper it must be classified as a ramp. This means that a gradient between 1:20 and 1:15 should have a slip-resistant surface and handrails. A maximum gradient of 1:12 can be used if the length is not greater than 5m.

External steps have lower risers and longer treads than those used internally. Handrails should always be provided no matter how short the flight, and minimum landings of 1500mm clear should be provided at the top and bottom. To assist visually impaired visitors tactile, textured ribs should be provided parallel to the

top of each flight to warn of the presence of a tripping hazard.

Deterrent paving

Careful thought and design can eliminate the need for deterrent paving. It is often unsightly and difficult to maintain.

Car parks

Gradients for drainage should be consistent and avoid sharp changes in level in areas of adjacent paving or planting. By keeping the levels simple, construction costs are reduced and the surfaces are more user-friendly.

Overflow car parks

Occasionally, at times of increased use, areas will need to be designated to accommodate additional car parking. Surfacing can be gravel or reinforced grass. Reinforced grass can be a concrete or plastic matrix that allows grass to grow within cells of rigid material, or plastic mesh worked into topsoil that is seeded in the conventional way.

None of these options is particularly cheap and all must be installed on a compacted sub-grade. If very occasional parking is required in the summer months grassed areas can be used.

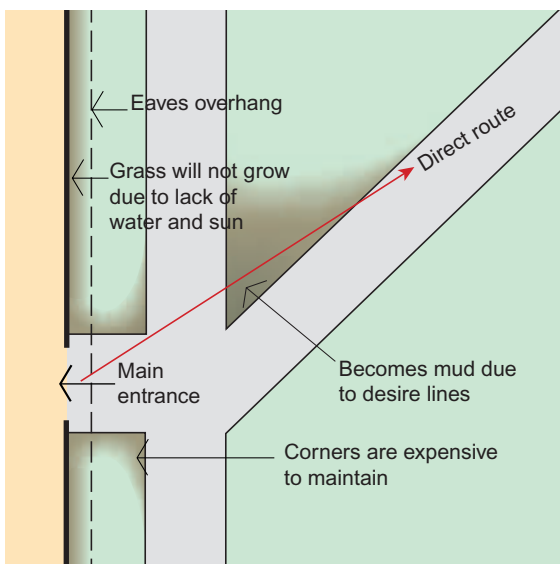

Plan pathways to follow a direct route, avoid sharp corners and ensure planting has sufficient light.



Example of a durable bay marking in granite setts.



Site furniture

Furniture must be robust. Simple designs are often preferable as they tend to be stronger and easier to replace if damaged. Careful selection can reduce costs and enhance the appearance of a facility. Site furniture comes in a bewildering array of styles, colours and materials. Steel, cast-iron, timber (hardwood and softwood) and recycled plastic are some of the materials available and consideration should be given to appearance, cost, lifespan, source and maintenance. Hardwoods must be from a sustainable source. Steel is strong, but if painted will need repainting. Galvanised or polished aluminium finishes are perfectly acceptable and reduce maintenance costs.

Bollards

Bollards are used to guide and control traffic and illuminated models are available. They must be used sparingly as they can be expensive, hinder and obstruct circulation and be visually intrusive. Good design can reduce dependency on bollards. For example, could a raised kerb do the job just as effectively? In certain locations coloured bollards may be easier to see.



Concrete bollards.



Timber bollard with markings to improve visibility and stainless steel bollards.

Litter bins

Bins should be located to avoid damage from vehicles and discomfort to users arising from unpleasant smells. Maintenance costs will be reduced by ensuring that they are well positioned and emptied regularly. When selecting a waste bin look for one that is durable and easily emptied. Remember that plastic bins are flammable.

Chewing gum and cigarette dispensers carefully positioned next to the entrance help reduce cleaning and maintenance costs. Bins may also be required for dog litter.



Types of waste bin.

Seating

For what purpose are the seats intended? Will they be located in the waiting area or are they for people watching events? Note that elderly people prefer seats with backs and arms to assist sitting and standing. The location, user and intended use need to be considered. Are the seats to be placed in the sun or in the shade? Are they for spectators or players?

The materials used will make the surface warm or cold: metal and stone seating is cold, timber is warmer. Like bins, seats should have secure below ground fixings.



Types of bench.

Signage

Signs are important sources of information and reinforce the image of facilities. They should advise people of opening times, entrance fees and any restrictions in force. This information must be accessible to the public even when the facility is closed. All signs should be part of a comprehensive signage system that has been carefully considered to ensure they are:

- carefully located with minimal clutter
- clear, simple and logical
- non-reflective.

Lighting

Lighting will usually be required for car parks and footpaths. It may also be required for flood-lighting pitches. Avoid light pollution not only for the benefit of local residents but also for wildlife. This is particularly important if the facility abuts any form of nature reserve or valuable wildlife habitat. Avoid sodium (yellow) light. Light fittings should be chosen to direct light down to where it is required. Floodlighting should always be directed away from residential and nature conservation areas. Planting can help reduce reflected glare from large areas of paving.

Lighting is critical for security and safety. It is preferable to achieve a consistent low level of light rather than high levels of light in pools that cause shadows.

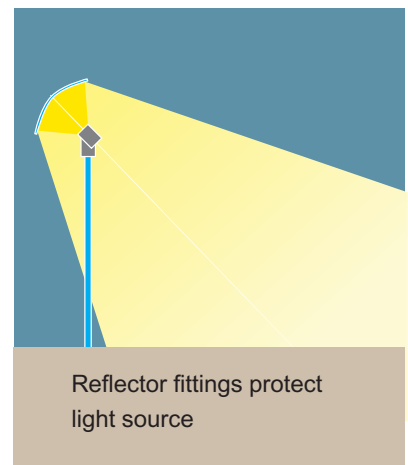
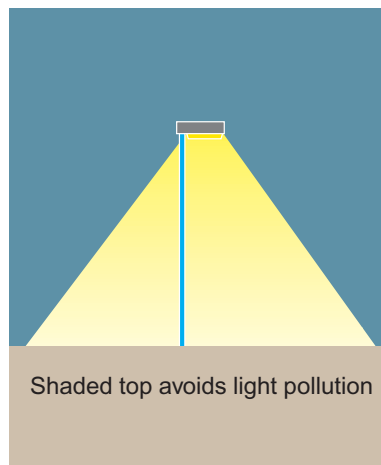
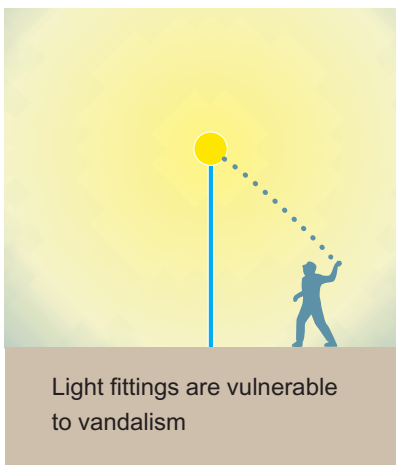

Choose light fittings to avoid light pollution.



Types of light fitting.

Structures

These may be required in the form of bin stores, cycle racks, maintenance sheds or pergolas. They should be considered as part of the overall design of the facility.

Bin stores: site for ease of access from the facility and for easy refuse collection. They need to be located away from main circulation areas and screened from view. Timber fencing is usually appropriate.

Cycle racks: preferably located near the main entrance, in full view and under cover. The local authority, will usually advise on the number of spaces required.

Maintenance sheds: site to provide clear access to sports pitches. If appropriate, dropped kerbs should be provided to allow ease of access for vehicles. Visibility needs to be good to avoid potential conflict between vehicles and pedestrians.



Gabion retaining wall using metal basket containing stone and rock.

Pergolas: these are good for providing shade when covered with climbing plants, particularly if it is not possible to plant trees or they are considered inappropriate.

Level changes

Any construction work will increase costs. Occasionally, it is necessary to build retaining walls to take up level changes but, with a little thought, slopes with grass or shrubs or a combination of slopes and retaining walls can be used.

If an element of screening is required, it can sometimes be achieved with ground form and mounding rather than walls and fencing. Ground form can often be more sympathetic and can be used as a way to avoid taking material off-site, which is expensive. However, this is a skilled operation and advice should be sought to prevent the ground form appearing alien and artificial. The gradient of slope must be considered in practical and safety terms.

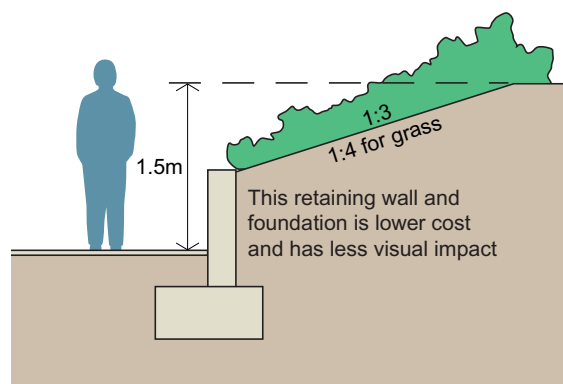
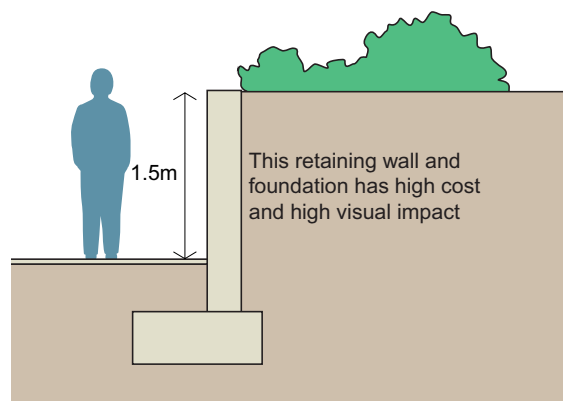

Retaining walls.

Water disposal

Water is a precious resource and must be used wisely. Water resource management together with plant species selection and management, are critical considerations when planning external areas.

Determine where services enter the site early on in the planning process. Underground drainage can be expensive and is often unnecessary. Try to avoid lengthy runs of pipework to save on expensive excavations and movement of materials.

If at all possible water run-off from paving, roofs, and pitches should be directed to soak-aways, balancing ponds or existing water courses. However, check first with the local Environment Agency office.

Large car parks create extensive areas of water run-off and these must be taken to a petrol interceptor.

Planting – detail design

The term ‘soft landscape’ is sometimes used to describe areas of grass and planting.

Plants are used to provide colour and texture to make sites attractive, and to perform particular functions such as screening, defining routes, marking edges or to provide shelter and shade.

If correctly specified and planted trees and shrubs incur minimal maintenance costs. The planting season runs from October to March, however the best time to plant is in the autumn. For cost-efficiency and to avoid waste the building programme must take this into consideration,

Grass

Although grass is relatively inexpensive to establish, regular mowing and maintenance costs are high. A wildflower meadow may be an appropriate alternative to close-mown grass and will thrive on poor quality soils thereby omitting the need for topsoil. Meadows require only one or two cuts per year but all cuttings must be removed.

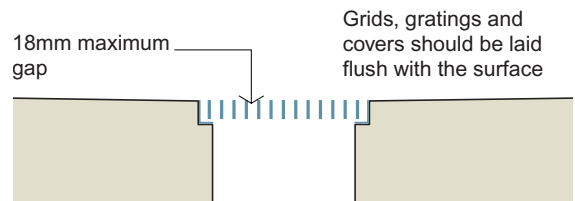
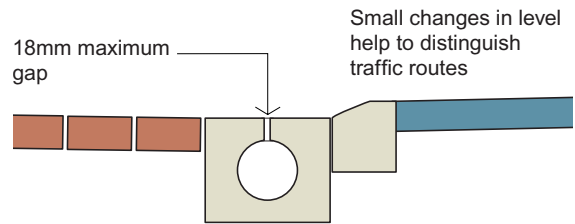
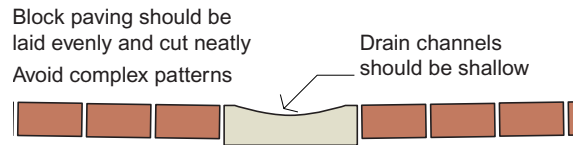

Drainage channels should be flush with the surrounding surface.

Grass can be established using turf or seed. Seed is cheaper but takes longer to establish itself and is best sown in the autumn. Turf is more expensive but the effect is instantaneous. Additionally, turf will better tolerate being laid in the spring or summer, although this should be avoided.

The maximum gradient for grass slopes is 1:4 for safe mowing. Grass for pitches, bowling greens and tennis courts is dealt with in detail in a separate Guidance Note.



Planting to the perimeter of a building can protect external walls from graffiti and damage.

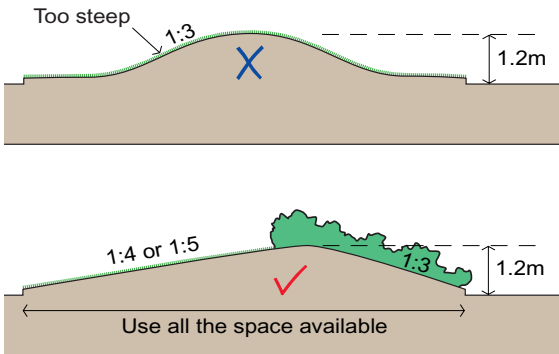

Avoid steep slopes.

Shrubs

Shrubs add colour and texture and low shrubs can be an alternative to grass. Climbing plants are a cheap way of screening service areas or for covering blank walls. Shrubs should not be taller than 0.5m in areas where clear visibility is required alongside footpaths or in car parks, for example. Tall shrubs are suitable along boundaries and against buildings where they can act as deterrents to graffiti.

It is sometimes tempting to plant fast-growing species such as leyland cypress or Russian vine, but these can cause maintenance difficulties later. If in doubt seek advice from a landscape architect.

The selection of species is usually based on criteria such as growing conditions: type of soil, sun/shade, rainfall and so on, appearance, size and availability. It is necessary to decide whether ornamental species such as lavender or firethorn, or native species such as hawthorn and hazel are most appropriate. This is usually dependent on the location of the site, cost and the final desired effect.

Essentially, shrub planting is most effective when it is used simply and in scale with its surroundings. It is perfectly acceptable to use bold blocks of the same species saving isolated specimens to mark entrances or routes. In schemes that are intended for public use, species should be robust and able to withstand damage. This is usually achieved by selecting those that are readily available and not too

ambitious. For example, choose *Ilex aquifolium* when selecting holly rather than *Ilex aquifolium* 'Golden van Tol', which may only be available through a specialist supplier.

Use peat-free composts. If the use of herbicides is unavoidable, ensure they are biodegradable.

Hedges and hedgerows

'Hedge' is usually the term given to a clipped or ornamental hedgerow. Hedges normally comprise one or two species such as firethorn, beech or berberis, whereas hedgerows are normally native plants comprising four or more species that might include blackthorn, hawthorn, hazel, elder and often tree species such as ash or oak.

Hedges are a potentially low cost alternative to fences or walls. Hedgerows should be allowed to grow naturally and will therefore need more space and less maintenance than a clipped hedge.

Trees

Trees can filter dust and provide shelter and shade. They can be relatively inexpensive and give an instant effect. Although they obstruct visibility only marginally at eye level, they may obstruct the vision lines of security cameras. The siting of cameras is therefore critical and, if they are to be installed, should be considered as part of the overall design concept.



Simple, bold planting can be effective and require low maintenance.

Trees help assimilate new buildings into their surroundings. The size of trees when they are planted depends on budget, location and required effect. They tend to establish better when planted young, but this means they are more susceptible to vandalism and the effect takes longer to achieve.

Remember that all trees, even conifers, drop their leaves. Deciduous trees, for example oak and ash drop their leaves in autumn, providing light in winter and shade in summer.

When considering the foundations of new buildings and other structures take into account the roots of existing and newly planted trees. It is important to consider problems that fast growing varieties may cause at a later date. Trees with a high water uptake such as poplar or willow may also cause problems later, however if used correctly they can help with water management.

Carpet bedding

Carpet bedding can be very attractive. It is, however, labour-intensive not only during planting but also because of the level of day-to-day maintenance required, neither is it sufficiently robust. For these reasons it is considered inappropriate for sports facilities in terms of value for money.

Soils

Every effort should be made to conserve any existing topsoil on the site. It may be necessary to obtain a chemical analysis to help identify the quality of the topsoil.

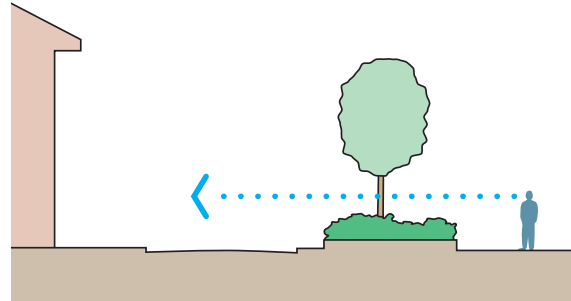

Visibility is maintained below the tree canopy.

Topsoil for planting should generally be spread to a depth of 400mm for shrubs and 100–150mm for mown grass. The finished level of topsoil after settlement should be 30mm above surrounding paving. It is also important to consider the quality of any imported fill required to make up levels.

Topsoil retained for reuse should be stored on-site in heaps no taller than 1.5m. Once topsoil has been spread, heavy machinery and vehicles should be prohibited to avoid compaction.

Newly planted areas should be covered with a minimum of 50mm of bark mulch.

Protection of planting

New planting can be vulnerable to vandalism and accidental damage. It is sometimes necessary to protect new plants with temporary fencing. The fencing usually remains in place until the plants have become established about 12–15 months after planting.

In some locations new planting may also need to be protected from deer and rabbits.

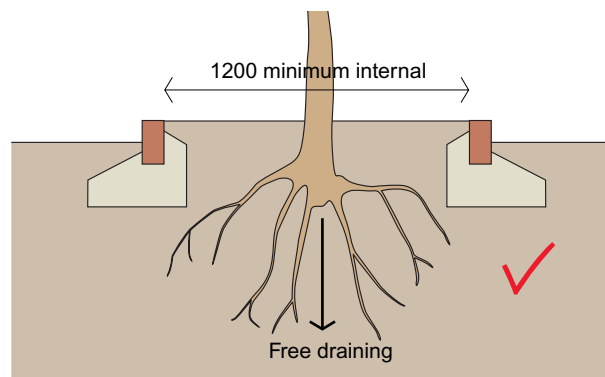
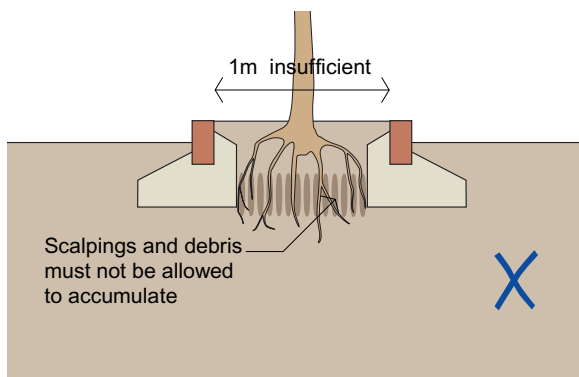

Tree roots like width rather than depth so give them as much space as possible.



Maintenance

Landscapes need to be maintained and managed to conserve investment. However, with some thought costs can be kept to a minimum. It can be tempting to reduce maintenance operations to minimise costs. Don't! This will only incur higher costs later on.

Grass

Although cheap to establish, grass is expensive to maintain.

Shrubs

If planted correctly at the right size and density little or no maintenance should be required after two years. It is critical that weeds are controlled during the establishment period and that, if necessary, the shrubs are watered in times of drought.

Trees

Trees need minimal maintenance. From time to time they must be inspected for rot and disease. Advice can be obtained from local authority tree officers or from an arborist.

Plants need to be protected if they are going to establish themselves successfully. It is usual for a 12- or 24- month maintenance contract to be locked into a planting contract. Failure to



A wildflower meadow may be especially suitable in a rural location.

include a maintenance contract can nullify guarantees that the landscape contractor would otherwise give.

Sustainability

The Government has a vision of sustainable development:

- effective protection of the environment
- prudent use of natural resources.

Biodiversity is an intrinsic part of sustainable development. It is about conserving and improving the richness of our natural habitats. Sport England believes that these objectives should be met wherever possible in the design of sports facilities. Consideration of these issues, including materials used and appropriate long-term maintenance, must be given to all aspects of design.

Cost planning

It is crucial, as for all aspects of a building project, that adequate funds are allocated to the external works at the outset. These costs need to be reviewed periodically as the project progresses. A chartered landscape architect can assist with this. More complex projects may benefit from the additional involvement of a chartered quantity surveyor.



Use bold blocks of planting and plant to the edge.

Construction on-site

Good planning during the construction phase will protect existing features such as trees and hedgerows. It is important to protect any trees that are to be retained, at least in accordance with current British Standards. Define clearly how the works are to progress, together with temporary roadways and the location of fencing to control site vehicles.

The risk of fire and correct storage of materials must also be controlled. Tipping of waste must not be permitted and the contractor must demonstrate that excess materials will be disposed of correctly off-site.

Newly planted trees, shrubs and new turf must be protected from the activities of trades and sub-contractors. Vehicles must not be allowed to cross topsoil and controls must be in place to avoid excess compaction. Much of this is common sense and can be applied through competent site management.

To avoid excessive land-take, try to ensure that temporary surfaces are located where permanent areas of paving or structure are planned – this will eliminate waste and reduce costs. It will also ensure a more successful scheme at the end of the day.

Programming of the works is critical. It is most important to plant trees and shrubs at the correct time of year, that is from October to March. While planting is possible outside this period it can entail constant watering or result in excessive and unnecessary plant losses,



A poor example of tree protection. It is essential to safeguard trees during site works.

or both. It is much more cost-effective and sustainable to delay planting if the building programme does not correspond with the planting season.

Consultants

Chartered landscape architect

One way to help ensure that best value is achieved for landscape proposals is to seek specialist advice for all or part of the project. Chartered landscape architects work in a similar way to engineers and architects. They offer technical expertise and design skills, often working on projects from inception to completion and beyond. They can assist with planning applications, particularly if the proposed development is in an environmentally sensitive area.

Depending on the size of the project it may be appropriate to engage a chartered landscape architect for part of the scheme to advise on specific aspects such as planting.

For further information contact the Landscape Institute (telephone 0171 738 9166).

Other consultants

A chartered landscape architect will be able to advise when other specialists are required. These may include:

Engineers: to assist with civil engineering, retaining walls or water management.

Quantity surveyors: to assist with cost planning on complex projects.

Arborists: to advise on tree-retention and management.

Ecologists: to advise if the site is of a particularly sensitive nature.

Planning supervisors: projects over a certain size are subject to a statutory obligation to appoint a planning supervisor to oversee health and safety issues.

All these experts can be brought in for short periods for specific aspects of a project or be involved for the whole scheme, depending on the complexity of the task.



Attractive planting can significantly improve the appearance of sports buildings.

Sport England aims to lead the development of sport in England by influencing and serving the public, private and voluntary sectors. Our aim is:

more people involved in sport

more places to play sport

more medals through higher standards of performance in sport

Sport England Disclaimer

Every effort has been made to ensure the accuracy of the information contained in this publication. Sport England, its servants or agents shall not at any time, in any circumstances, be held responsible or liable to any party in respect of any loss, damage or costs of any nature arising directly or indirectly from reliance placed on the material in this publication, or any other guidelines or policies issued by Sport England. This information has been prepared as a basic guide only and should not be viewed as a substitute for obtaining comprehensive expert or professional advice.

This guidance and Sport England policies on Lottery funding applications are subject to change from time to time, including variations required to comply with governmental directions on the application of Lottery funds. Sport England reserves the right to amend, supplement and/or discontinue, at its absolute discretion for whatever reason, any or all of the guidelines set out in this publication.

There are a number of Guidance Notes on related matters. A current list is available from:

Sport England Publications
PO Box 255, Wetherby LS23 7LZ
Tel: 0990 210255. Fax: 0990 210266

© Sport England, July 1999

SE/886/5M/7/99

16 Upper Woburn Place, London WC1H 0QP

Tel: 020 7273 1581. Fax: 020 7273 1710

www.english.sports.gov.uk



Sport England is the brand name of the English Sports Council which is the distributor of Lottery funds to sport.

Design concept by GDA Creative Solutions

Produced by NBA Tectonics

Printed in England by Belmont Press



Ref: 886
£10
ISBN 1 86078 101 2